

LOC		DIST		REVISIONS			
P	LTR	DESCRIPTION	DATE	DWN	APVD		
D		REVISED PER ECO-06-014732	13NOV06	KW	DC		

- 1 MATERIAL:
HOUSING: NYLON, UL94V-0 (COLOR - NATURAL, COLOR OF PARTS MAY VARY).
CONTACTS: 0.25 THK COPPER ALLOY.
- 2 CONTACT FINISH: 0.003 MIN THK TIN-LEAD OVER 0.00127 MIN THK NICKEL OVER ENTIRE CONTACT.
- 3 CONTACT FINISH: 0.00076 MIN THK GOLD PLATE ON PIN MATING SURFACE, 0.003 MIN THK TIN-LEAD PLATE ON SOLDER TAIL, ALL OVER 0.00127 MIN THK NICKEL BASE PLATE.
- 4 SOLDER TAIL MEETS AMP SOLDERABILITY SPECIFICATION 109-11-2.
- 5 MATES WITH SIMILARLY PLATED AMP-DUAC™ POWER CONNECTOR RECEPTACLE HOUSINGS/SOCKET CONTACTS.
- 6 RIBS ON FOUR CORNERS OPTIONAL.
- 7 AMP LOGO AND MATERIAL ID MAY BE LOCATED ON EITHER LONG SIDE OF PART.
- 8 SIZE, SHAPE OR STYLE OF THIS FEATURE MAY VARY.
- 9 CONTACT FINISH: 0.003 MIN THK TIN OVER 0.00127 MIN THK NICKEL OVER ENTIRE CONTACT.
- 10 CONTACT FINISH: 0.00076 MIN THK GOLD PLATE ON PIN MATING SURFACE, 0.003 MIN THK TIN PLATE ON SOLDER TAIL, ALL OVER 0.00127 MIN THK NICKEL BASE PLATE.

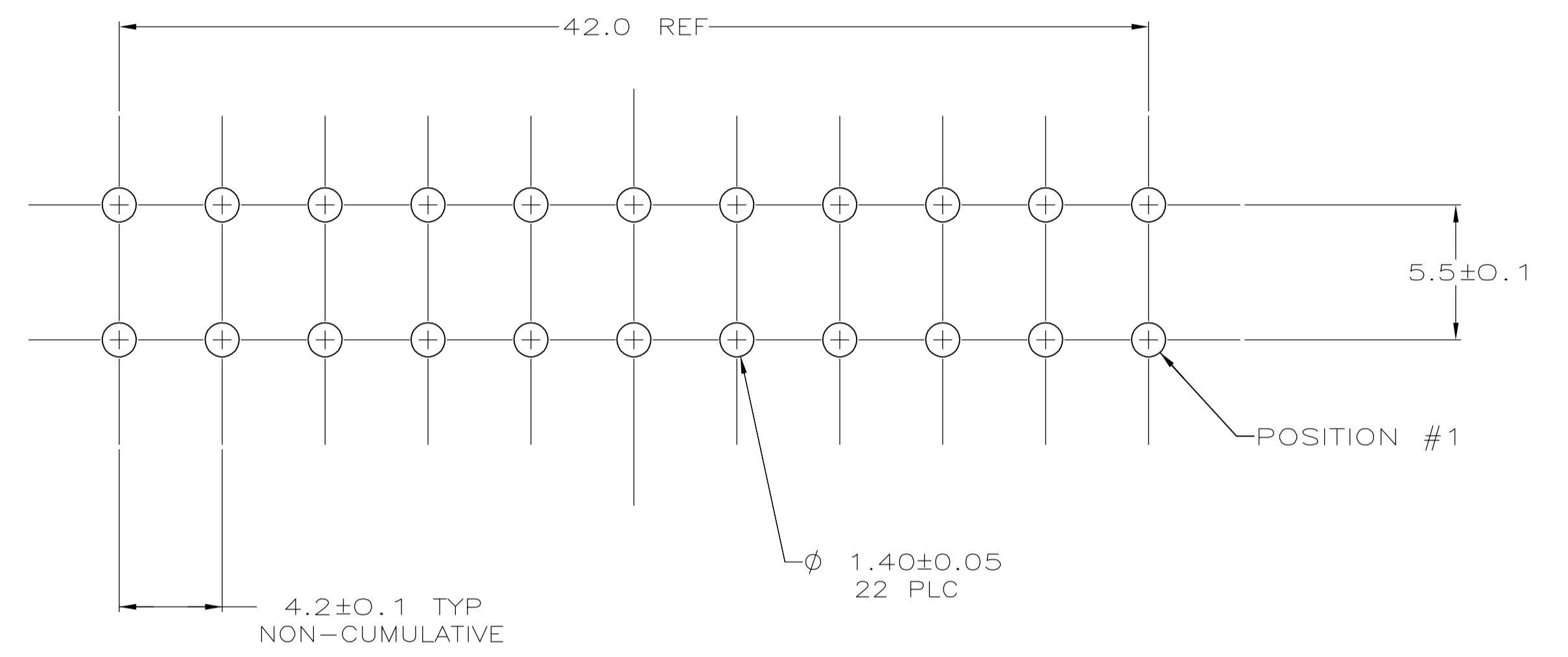

RECOMMENDED MOUNTING HOLE PATTERN FOR 1.78 MAX THICK P.C. BOARD COMPONENT SIDE SHOWN

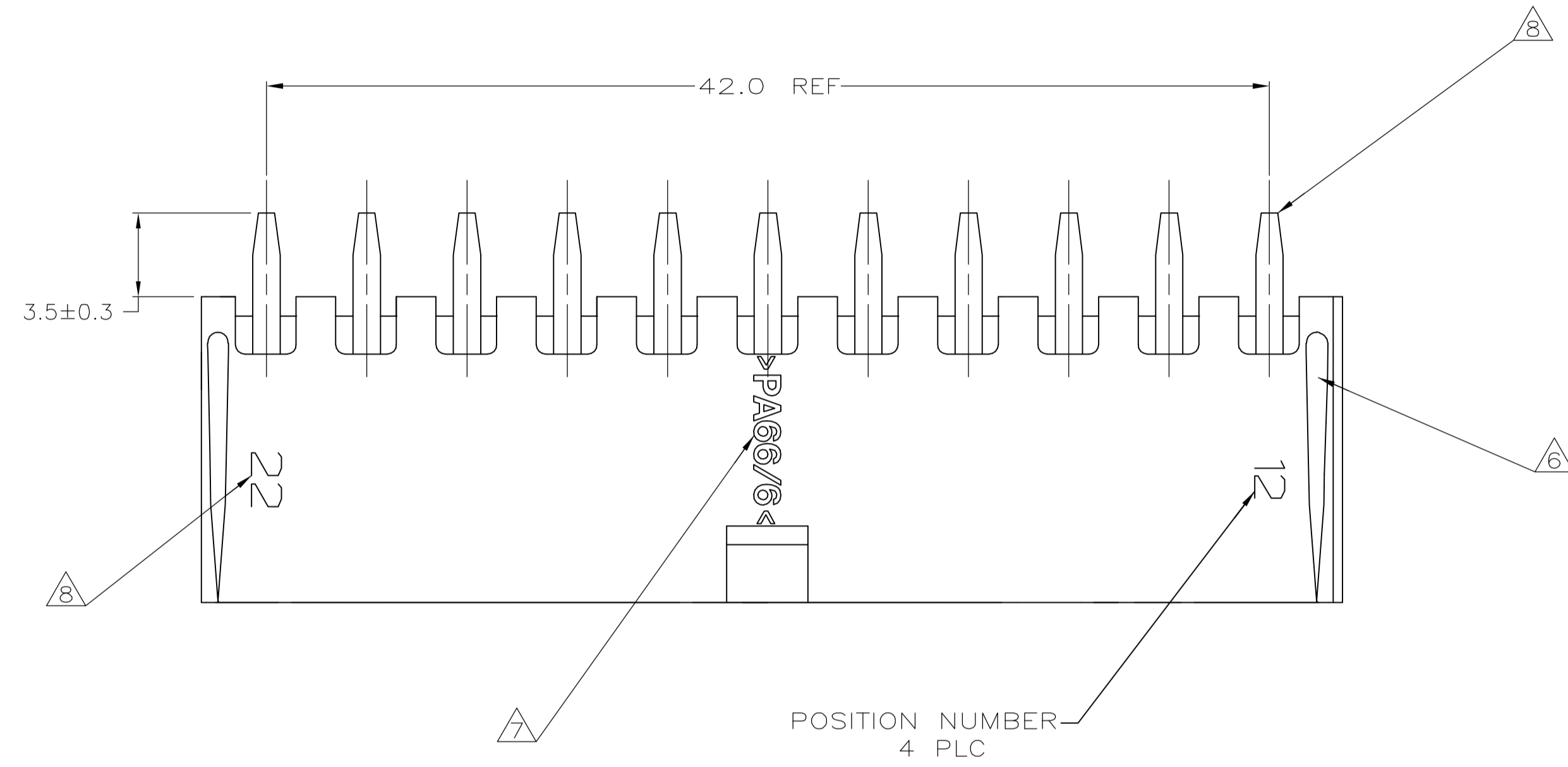
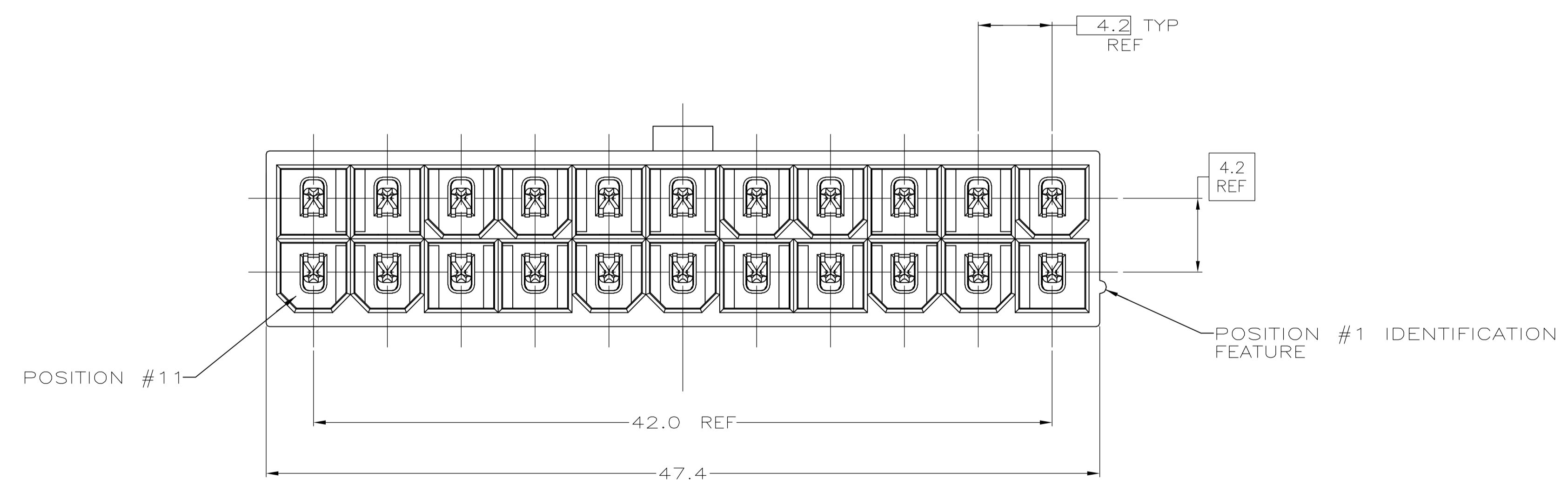
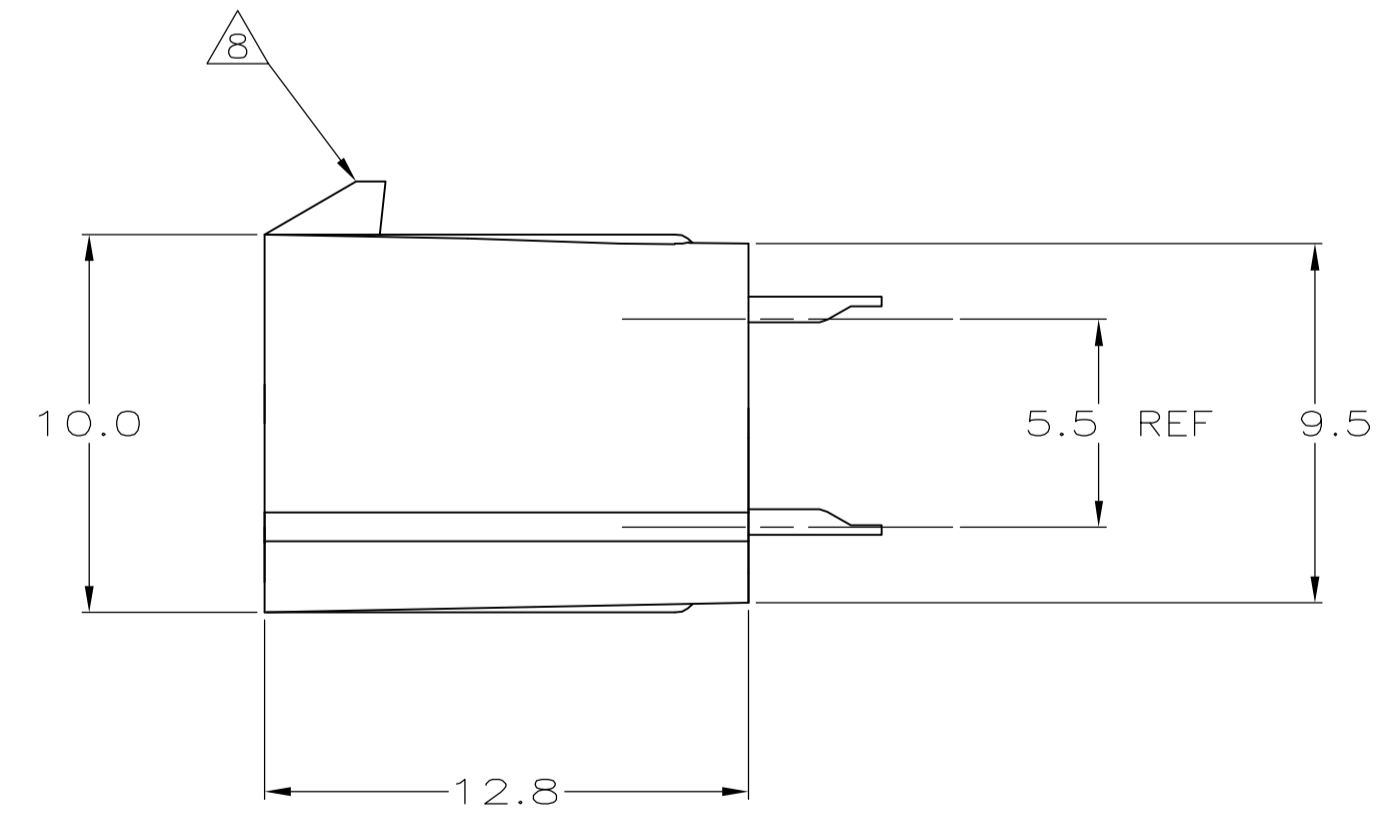

SUPERSEDED BY 1-794493-2
 SUPERSEDED BY 1-794493-1

CONTACT MATERIAL	CONTACT FINISH	HOUSING MATERIAL	HOUSING COLOR	PART NO
1	10	1	1	1-794493-2
1	9	1	1	1-794493-1
1	3	1	1	794493-2
1	2	1	1	794493-1

METRIC

THIS DRAWING IS A CONTROLLED DOCUMENT.

DIN R VESTAL 6-11-98		Tyco Electronics Corporation Harrisburg, Pa 17105-3608
CHK R SWING 6-11-98		NAME
APVD C CASH 6-11-98	PRODUCT SPEC	ASSEMBLY, HEADER, VERTICAL, 22 POSITION, W/DRAIN HOLES, 94V-0,AMP-DUAC(TM)
	APPLICATION SPEC	108-1699
	SIZE	A1
	WEIGHT	00779
	CUSTOMER DRAWING	794493

SCALE 5:1 SHEET 1 OF 1 REV D